

WARRICK COUNTY BOARD OF COMMISSIONERS MEETING
REGULAR SESSION
COMMISSIONERS MEETING ROOM
107 W. Locust Street, Suite 303
Boonville, Indiana
December 13, 2021
4:00 P.M.

The Warrick County Commissioners met in regular session with Robert Johnson, Vice President; and Dan Saylor, Member. President Terry Phillippe was not present for this meeting.

Attorney Todd Glass and Administrator Roger Emmons were in attendance.

Auditor Debbie Stevens and Secretary Kristine Georges attended and recorded the minutes.

Vice President Robert Johnson called the meeting to order at 4:00 PM.

PLEDGE OF ALLEGIANCE

Commissioner Johnson: Thank you. Commissioner Phillippe felt ill this afternoon. So, it's just Commissioner Saylor and myself.

**AREA PLAN COMMISSION
REQUEST TO REZONE
PC-R-21-10
ORDINANCE 2021-37**

Commissioner Johnson: So, first up we have APC. Molly, you want to take over?

Molly Barnhill: Yeah, we have one (1) Request to Rezone. It's Docket PC-R-21-10. Petitioner and owner is Kathleen A. Sweat to rezone two point six-nine (2.69) acres located on the west side of Brackridge Lane, zero (0) feet northwest of Brackridge Lane and Duncan Street from M-2, General Industrial Zoning District to A, Agricultural. Being Lot 19 in the Town of Folsomville Subdivision and a part of Owen Township 34-4-7. This was advertised in the Standard on October 25, 2021. And the APC gave a unanimous positive recommendation to the Commissioners to approve PC-R-21-10 at their meeting on November 8, 2021.

Commissioner Johnson: Anybody here?

Molly Barnhill: Yes. Kathleen, you want to come up, please?

Commissioner Johnson: Hello, Ma'am. Please state your name.

Kathleen Sweat: Kathleen Sweat.

Commissioner Johnson: Okay, do we have an Ordinance number?

Kristine Georges: Yes, the Ordinance number would be 2021-37.

Commissioner Johnson: Okay. We're gonna rezone this from M-2 to Agriculture? Correct?

Molly Barnhill: Yes. I believe it's where the old, is it the old school building was?

Commissioner Johnson: The old school?

Molly Barnhill: Yeah.

Commissioner Johnson: Okay.

Todd Glass: Anyone for or against?

Commissioner Johnson: Yeah, are there any remonstrators here for or against this project? I see none. Commissioner Saylor, you got any questions?

Commissioner Saylor: I don't. I make that, I make a motion to approve the request to rezone, PC-R-21-10.

Commissioner Johnson: And I'll second for Ordinance 2021-37.

Commissioner Saylor: Thank you.

Commissioner Johnson: All in favor?

Commissioner Saylor: Aye.

Commissioner Johnson: Aye. (Motion carried 2-0). There you go, Ma'am.

Kathleen Sweat: Thank you.

Todd Glass: Commissioner Johnson, with two (2) Commissioners, I'm not sure about Zoning Ordinances, but I know all Ordinances with only two (2) Commissioners here can be approved on First Reading. I'm not sure about zoning.

Roger Emmons: Might have to bring it back then on the 27th?

Todd Glass: For a Second Reading.

Molly Barnhill: Really? It doesn't just need a majority?

Todd Glass: Not on Ordinances.

Roger Emmons: Not an Ordinance.

Todd Glass: Again, I'm not sure if there's any exceptions to zoning.

Bobby Howard: There may be, cause I thought that there was some discussion about that a few years ago. Because at that time they were trying to have all the zoning be read twice and I think the APC attorney had a different take on it.

Todd Glass: I can check with Morrie, but you've taken action on it and voted two (2) to zero (0) on it. So, if it's valid, it's valid. But, I just wanted to warn you about that.

Commissioner Johnson: Okay, thank you.

Commissioner Saylor: So, you'll check on that and get back, and Morrie's got something else to talk to you about too Okay.

Todd Glass: Yes, yes. Okay.

Commissioner Johnson: Okay.

(Ordinance 2021-37 is located on Page 18 of these Official Minutes)

STREET CONSTRUCTION PLANS PP-21-17 OAK GROVE INDUSTRIAL

Molly Barnhill: Our next item would be Street Construction Plans. First one's PP-21-17, Oak Grove Industrial. Petitioner/Owner is Oak Grove Industrial, LLC, by Walter L. Howard. It's approximately thirty-three point seven (33.7) acres on the west side of Epworth Road. Eight hundred (800) feet south of the intersection of Oak Grove Road and Epworth Road. Ohio Township, 20-6-9, advertised in the Standard on December 2, 2021. The County Engineer has reviewed the dollar amount and signed off on that part of it.

Commissioner Johnson: Bobby, are you okay?

Bobby Howard: Yeah, the street plans are in compliance with our Ordinance, so I'd recommend approval.

Commissioner Saylor: I make a motion to approve street plans, construction plans PP-21-17.

Commissioner Johnson: I'll second. All in favor?

Commissioner Saylor: Aye.

Commissioner Johnson: Aye. (Motion carried 2-0).

Glen Meritt: Thank you.

(PP-21-17 is located on Pages 18 through 19 of these Official Minutes)

PP-21-18 DEER CREEK SUBDIVISION

Molly Barnhill: Next one (1) is PP-21-18. It's Deer Creek Subdivision. Petitioner/owner is KSKS Development, LLC by Kurt Phillips, the Agent. Approximately thirty-eight point one (38.1) acres on the east side of Stevenson Station Road. Zero (0) feet southeast of the intersection formed by Ayrshire Road and Stevenson Station Road. Campbell Township, 29-5-9 and 32-5-9. It was advertised in the Standard, December 2, 2021. They're requesting no improvements to Ayrshire Road and Stevenson Station Road. But, they have filed plans for the shared driveways as part of this development.

Jim Morley, Jr.: Jim Morley...

Commissioner Johnson: Anything to add, Mr. Morley?

Jim Morley, Jr.: Nope, just here to answer any questions.

Commissioner Johnson: Bobby?

Bobby Howard: I recommend approval. The shared driveways are in general compliance with that whole area. They have several lots. So, the west side of the road has a shared drive.

Commissioner Johnson: This is a shared drive on the right hand side of the road?

Jim Morley, Jr.: Yeah, so, they'll have a common pipe and then a shared drive on every other lot line.

Commissioner Johnson: Okay.

Bobby Howard: We have a dollar amount for that to be held until those are constructed. Those will be constructed by the developer in this case.

Commissioner Saylor: So, is that going to be, is that going to be a solid pipe from there to there, Jim?

Jim Morley, Jr.: No, it's just thirty (30) feet of pipe or whatever on each drive.

Commissioner Saylor: Okay.

Jim Morley, Jr.: So, it's open ditch and then you just put a pipe in (inaudible) across the lot line.

Commissioner Saylor: Okay. Okay. I didn't know how. Okay.

Commissioner Johnson: Any further questions, Commissioner Saylor?

Commissioner Saylor: I don't think I have any. I make a motion to approve the street construction plans for PP-21-18.

Commissioner Johnson: I'll second. All in favor?

Commissioner Saylor: Aye.

Commissioner Johnson: Aye. (Motion carried 2-0).

Commissioner Saylor: Thank you.

(PP-21-18 is located on Pages 20 through 21 of these Official Minutes)

PP-21-19 GOLDEN POND ESTATES

Molly Barnhill: Next up is PP-21-19, Golden Pond Estates. Petitioner/owner is Glenn E. and Judith A. Heseaman, approximately thirteen point nine-seven (13.97) acres on the north side of Titzer Road, nine hundred fifty (950) feet east of the intersection formed by Titzer Road and St. John's Road. Being Lots 1C and 2B in St. Johns-Titzer Subdivision, Campbell Township, 32-5-9. Advertised in the Standard on December 2, 2021, and they're requesting no improvement to Titzer Road or St. Johns Road.

Commissioner Johnson: Mr. Howard?

Bobby Howard: Recommend approval.

Commissioner Saylor: You good with it, Bob?

Commissioner Johnson: Yes, Sir.

Commissioner Saylor: I make a motion to approve the street construction plans for PP-21-19.

Commissioner Johnson: I'll second. All in favor?

Commissioner Saylor: Aye.

Commissioner Johnson: Aye. (Motion carried 2-0).

(PP-21-19 is located on Page 21 of these Official Minutes)

PP-21-20 HIGH POINTE CENTER NORTH SECTION 2 PUD

Molly Barnhill: Next is PP-21-20, High Pointe Center North Section 5 PUD. Petitioner/owner is Ortez...

Roger Emmons: Ayala.

Molly Barnhill: Ayala, okay, LLC, by Melvin Ortez the owner. Approximately three point four-four (3.44) streets located on the north side of High Pointe Drive, zero (0) feet northeast of the intersection of High Pointe Drive and Bell Road. Being a replat of Lot 1 in High Pointe Center North, Section 4 PUD, and part of Lot 40 in High Pointe Center North, Section 2. It's Ohio Township, 2-6-9. It was advertised in the Standard December 2, 2021. They're requesting no improvements to Bell Road and to High Pointe Drive.

Jim Morley, Jr.: So, I can tell you this is, Jim Morley, Project Engineer, this is two (2) fully developed lots. One (1) of them is the Acapulco Restaurant and the other one (1), I think, is like a Mr. Detail or something like that. And all we're doing is just adjusting the lot line between those two (2) lots to put all of the lakes on the Acapulco lot. And so no new, no new...

Commissioner Saylor: Okay.

Bobby Howard: Recommend approval.

Commissioner Saylor: I make a motion to approve PP-21-20.

Commissioner Johnson: And I'll second. All in favor?

Commissioner Saylor: Aye.

Commissioner Johnson: Aye.

Jim Morley, Jr.: Thank you.

Commissioner Johnson: Thank you, Mr. Morley.

Commissioner Saylor: Thanks, Jim.

(PP-21-20 is located on Page 22 of these Official Minutes)

**SUBDIVISION CONTROL ORDINANCE AMENDMENTS
AN ORDINANCE TO AMEND ARTICLE XII (B)-PLANNED UNIT DEVELOPMENT (PUD)
SECTION 2 GENERAL REQUIREMENTS SUBSECTION (A) PERMITTED USES IN PUD
DISTRICT OF THE COMPREHENSIVE ZONING ORDINANCE
ORDINANCE 2021-38**

Molly Barnhill: Okay, we have some Subdivision Control Ordinance Amendments. These were advertised in the Standard and they went to the Area Plan Commission. They were advertised October 28th. And the Planning Commission met. The first one (1) is an Ordinance to amend Article XII (B), Planned Unit Development (PUD), Section 2 General Requirements, Subsection (A) Permitted Uses in PUD District of the Comprehensive Zoning Ordinance in effect for Warrick County, Indiana. The purpose of this Ordinance is to add CON and AG to the PUD Districts in the Warrick County Comprehensive Plan. Excuse me, Comprehensive Zoning Ordinance. The APC gave a unanimous positive recommendation to the Commissioners at their meeting held on November 8, 2021.

Commissioner Johnson: Have you had time to review these, Commissioner Saylor?

Commissioner Saylor: I have. I've looked at them, Bob. I don't, I don't think I have any issues with them.

Commissioner Johnson: We formed a committee out of APC between Molly, Counselor Doll, myself, Amanda Mosiman.

Molly Barnhill: And these are actually in addition to what we did in the committee. This is one (1) that we talked about adding the agricultural and the conservancy to the PUD's, so it's part of that. We had to do it in a couple different places in the Ordinance to make them all match.

Commissioner Johnson: So, I have no issues with it. It helps streamline things and helps make things in APC a little bit smoother and easier.

Molly Barnhill: Yeah.

Commissioner Saylor: So, an Ordinance to amend, okay. So, this is not, okay, got it.

Roger Emmons: '38, Kristine?

Kristine Georges: Yes, Sir, it is.

Todd Glass: And again, we'll just have to look as to the effective date on a vote of two (2) to zero (0), if that's what the Commissioners' do.

Roger Emmons: Right.

Commissioner Saylor: Okay. I make a motion to approve the Subdivision Control Ordinance amendment for Ordinance 2021-38.

Commissioner Johnson: And I'll second. All in favor?

Commissioner Saylor: Aye.

Commissioner Johnson: Aye. (Motion carried 2-0).

(Ordinance 2021-38 is located on Page 23 of these Official Minutes)

**AN ORDINANCE TO AMEND ARTICLE VII – RECREATION AND CONSERVANCY “CON”
DISTRICT SECTION 1 USE AND REGULATIONS OF THE
COMPREHENSIVE ZONING ORDINANCE
ORDINANCE 2021-39**

Molly Barnhill: The next one (1) goes with the first one (1). It's an Ordinance to amend Article XII, Recreation and Conservancy "Con", I'm sorry. It's VII, Recreation and Conservancy "CON" District, Section 1 Use and Regulations of the Comprehensive Zoning Ordinance in effect for Warrick County. This was to add the PUD as permitted in the "CON"

Zoning in the Warrick County Comprehensive Zoning Ordinance and the APC gave a unanimous positive recommendation at their November 8th meeting as well.

Commissioner Johnson: This would be Ordinance '39?

Roger Emmons: Yep.

Commissioner Saylor: Motion? I make a motion to approve the amendment Ordinance 2021-39.

Commissioner Johnson: And I'll second. All in favor?

Commissioner Saylor: Aye.

Commissioner Johnson: Aye. (Motion carried 2-0).

(Ordinance 2021-39 is located on Page 23 of these Official Minutes)

AN ORDINANCE TO AMEND ARTICLE VII – AGRICULTURAL “A” DISTRICT SECTION 1 USE AND REGULATIONS OF THE COMPREHENSIVE ZONING ORDINANCE ORDINANCE 2021-40

Molly Barnhill: Next one's an Ordinance to amend Article VII, Agricultural "A" District, Section 1 Use and Regulations of the Comprehensive Zoning Ordinance in effect for Warrick County, Indiana. This was to add PUD as a permitted use in the "A" Zoning in the Warrick County Comprehensive Zoning Ordinance and it received a unanimous positive recommendation on November 8th from the APC.

Commissioner Johnson: This would be Ordinance '40.

Commissioner Saylor: You good with it, Bob?

Commissioner Johnson: Yes, Sir.

Commissioner Saylor: I make a motion to approve the amendment to Ordinance 2021-40.

Commissioner Johnson: I'll second. All in favor?

Commissioner Saylor: Aye.

Commissioner Johnson: Aye. (Motion carried 2-0).

(Ordinance 2021-40 is located on Page 23 of these Official Minutes)

AN ORDINANCE TO AMEND ARTICLE XII(B)-PLANNED UNIT DEVELOPMENT (PUD) SECTION 8 SUBMISSION OF SUBDIVISION PLAT SUBSECTION (C) RECORDING OF FINAL PLAT OF THE COMPREHENSIVE ZONING ORDINANCE ORDINANCE 2021-41

Molly Barnhill: Our last one's Ordinance to amend Article XII (B), Planned Unit Development (PUD), Section 8 Submission of Subdivision Plat, Subsection (C) Recording of Final Plat of the Comprehensive Zoning Ordinance in effect for Warrick County. The purpose of this Ordinance was to amend the final plat timeline for PUD's to three (3) years from the one (1) year that is currently in the Zoning Ordinance. The APC gave a unanimous positive recommendation at their meeting on November 8, 2021.

Commissioner Saylor: Why was that, Bob, increased like for (inaudible)?

Commissioner Johnson: It's actually a decrease.

Molly Barnhill: Well...

Commissioner Saylor: It says PUD to three (3) years from one (1) year.

Molly Barnhill: The Ordinance has one (1) year in it now.

Commissioner Saylor: Uh huh?

Molly Barnhill: And this if for just PUD's. But, we've been practicing the same as we would a primary plat which is five (5).

Commissioner Saylor: Oh, okay.

Molly Barnhill: So, we wanted to make it a little more consistent.

Commissioner Saylor: Oh, I see. Okay.

Commissioner Johnson: Thank you for bailing me out on that one (1).

Commissioner Saylor: Understood. Alright. So, this Ordinance number is '41?

Commissioner Johnson: Yes, Sir.

Commissioner Saylor: I make a motion to approve the amended, amended Ordinance 2021-41.

Commissioner Johnson: I'll second. All in favor?

Commissioner Saylor: Aye.

Commissioner Johnson: Aye. (Motion carried 2-0).

Molly Barnhill: Okay, that's all for the Area Pan Commission.

Commissioner Johnson: Thank you, Molly.

Molly Barnhill: Thank you.

Commissioner Saylor: You done enough.

(Ordinance 2021-41 is located on Page 24 of these Official Minutes)

**ACTION ITEMS
APPROVAL OF MINUTES
NOVEMBER 22, 2021**

Commissioner Johnson: Next up, we have Approval of Minutes for November 22, 2021.

Commissioner Saylor: Hang on, Bob. I've got to get organized here. I think I'm okay with them. You good with them?

Commissioner Johnson: Yes, Sir.

Commissioner Saylor: I make a motion to approve the minutes for November 22, 2021.

Commissioner Johnson: I'll second. All in favor?

Commissioner Saylor: Aye.

Commissioner Johnson: Aye. (Motion carries 2-0).

**COUNTY ADMINISTRATOR
VOLUNTARY TITLE VI PUBLIC INVOLVEMENT SURVEY**

Commissioner Johnson: Next, we have our County Administrator. Roger, you're up.

Roger Emmons: Thank you, Mr. President. I'd first like to announce that on this table over here, we have Warrick County, Indiana, voluntary Title VI Public Involvement Survey. If anyone would be interested in helping the County's compliance with our Title VI Implementation Plan, feel free to fill those out and return it to this office.

**WARRICK COUNTY CORRECTIONS
FIREWALL REFRESH FROM KELLER SCHROEDER**

Roger Emmons: The first item I have is the Firewall Refresh quote from Keller Schroeder. It's #004464 Version 3. I emailed the Commissioners a copy of that on November 23rd. The quote is for thirty-four thousand eight hundred fifteen dollars and forty-eight cents (\$34,815.48). Dan replied that same day that he was okay with it and Terry signed it. It was supposed to be on the Consent Agenda, but for some reason it's not. So, I did find out from Dave Woolen this morning that EMA still hasn't received the signed grant agreement that will pay for this. But, they have received notification that it has been approved. So, you'd need a separate motion to approve this.

Commissioner Saylor: Okay, I make a motion to, or Commissioner Johnson, you good with it?

Commissioner Johnson: Yes, Sir.

Commissioner Saylor: Make a motion to approve the Firewall quote from Keller Schroeder.

Commissioner Johnson: And I'll second. All in favor?

Commissioner Saylor: Aye.

Commissioner Johnson: Aye. (Motion carried 2-0).

Roger Emmons: Thank you.

(Firewall Refresh Quote is located on File in the Auditor's Office)

AMERICAN LAND HOLDINGS EXTENSION OF TEMPORARY ROAD CLOSURE

Roger Emmons: Next is the continuing issue that American Land Holdings or Peabody regarding the extension of the agreement for temporary road closure for one point three-two (1.32) miles of Tecumseh Road and zero point three-two (0.32) miles of Eby Road in Hart Township. Jim McKeon, who's the land manager out there for Peabody's Wild Boar Mine, he sent an email December 2nd and I sent that to you that same day in an attachment. He basically stated the reason they needed the closure to be extended or requesting it to be extended is the effected roadways are still in use and not fully reclaimed or restored. And per the current agreement, we did receive their check in the amount of two thousand seven hundred forty-nine dollars and fifty-five cents (\$2,749.55) for the Eby Road Closure. That goes into one (1) of your discretionary line items in the Highway Donation Fund.

Commissioner Johnson: Roger, if you don't mind, I would like to table this one (1) until our next meeting.

Roger Emmons: Certainly.

Commissioner Johnson: Commissioner Phillippe is reaching out to American Land Holdings with a request and I'd like to entertain that request before we agree to this temporary road closure.

Roger Emmons: Need a motion to table.

Commissioner Saylor: I have a question before I make that motion. So, that check for twenty-seven-forty-nine-fifty-five (\$2,749.55), is that, is that for the anticipation of the closure or is that for what's been, is that retro-active?

Roger Emmons: No, that's, that's pursuant to the agreement that's in place right now.

Commissioner Saylor: Right now, had nothing to do with it...

Roger Emmons: For all of next year, that's the amount they pay for 2022.

Commissioner Saylor: Is that, do you check those figures, Bobby, when they come in? That they're paying us what....

Bobby Howard: Yeah, basically, they give their check in the beginning when they first close it, (inaudible) subsequent times for the following years.

Commissioner Johnson: So, let's hang on to that one (1) until we (inaudible).

Commissioner Saylor: Yeah, I make a motion to table the extension agreement for temporary road closure.

Commissioner Johnson: And I'll second. All in favor?

Commissioner Saylor: Aye.

Commissioner Johnson: Aye. (Motion carries 2-0).

Roger Emmons: That will be on your December 27th agenda then.

Commissioner Johnson: Thank you, Roger.

Roger Emmons: Thank you.

**CONSENT AGENDA
REQUEST FROM MR. WADE TAYLOR FOR PERMISSION TO BE ALLOWED TO TRAP
ON COUNTY PROPERTY**

Roger Emmons: Under the Consent Agenda, I don't know if there's any, anything I need to add there. The Board would just need a motion to, I did talk regarding the written permission to be allowed to trap on County property. Todd prepared the Hold Harmless and I think it's an Indemnification Agreement also. And Todd stated that it would serve as his written permission.

Commissioner Saylor: Hey, one (1), one (1) question about that, I know Bobby had concerns. What are we dealing with Bobby's, what are we doing with your concern about location and if they got one (1) at the edge, road edge or something, we mow it down with a mower?

Bobby Howard: I've asked to be notified before wherever they put them down.

Commissioner Saylor: I think that should be...

Roger Emmons: I think that's an excellent idea.

Commissioner Saylor: I think that should be part of the agreement that he has to notify them and give a map to, to Bobby so he can give to our mowers.

Todd Glass: I need a list of locations and I need to know how long of a term we're willing to grant.

Commissioner Saylor: I think there needs to be a map drawn so that he can give to that mower so he knows when he's going down that road, he, I mean, don't you think, Bobby?

Bobby Howard: Yeah.

Commissioner Saylor: Cause I can just see it now, we're going to be mowing up cages or traps.

Roger Emmons: Yeah, the Exhibit A currently hasn't any locations on it. So, I'd have to, I'd just, I guess we continue this to your next meeting and I get with Mr. Taylor and ask him to submit that.

Commissioner Saylor: Can we approve this with, with the, with the condition that he submits that, what we're requesting to Roger?

Todd Glass: You certainly can. You just also have to tell him how long the term is this agreement.

Commissioner Saylor: Well, I don't know, Bobby? The agreement with him?

Todd Glass: With him. How long? Is it a six (6) month? Is it a three (3) month? Is it a year?

Commissioner Johnson: Is it...?

Bobby Howard: Annually?

Todd Glass: Annual?

Commissioner Saylor: Do it on a renewal or an annual, he has to come back in front of the Board of Commissioners.

Roger Emmons: I think that's probably best, annually. Season to season.

Commissioner Saylor: Right. And, there's probably verbiage in there that he can, Bobby can cancel this agreement if it creates issues? Or we've got to have something in there where if, if you're going, what happens if you maintain a road or we're going to do roadside ditch. He has to have the ability to call him up and say, don't trap anything here.

Bobby Howard: Right.

Commissioner Saylor: So, I'd like to give Bobby the authority to...

Commissioner Johnson: I agree.

Commissioner Saylor: I don't want him to have to, I don't want to have to come back to the Board of Commissioners to get a trap cage removed or something. I think Bobby needs to have that authority.

Roger Emmons: So, should Bob and Dan sign this today, or does it need amending?

Todd Glass: I would suggest you pull it off the Consent and table it to the next meeting.

Roger Emmons: Gotcha. Thank you.

Commissioner Saylor: Okay. Does that need to be by motion?

Todd Glass: Consensus to put it off of Consent.

Commissioner Saylor: Okay, I'm good with it.

Commissioner Johnson: Let's pull it off of Consent, Roger.

Roger Emmons: Okay, gotcha.

**CONSENT AGENDA CONTINUED
CERTIFIED CLAIMS – NON-CERTIFIED CLAIMS
PAYROLLS – SHERIFF'S HOLIDAY PAYROLL
SPRINGBUK CONTRACT – OUTDOOR LIGHTING FOR JUDICIAL CENTER**

Roger Emmons: And then you'd need a motion to approve the remaining items on the Consent Agenda.

Commissioner Saylor: The Springbuk and then the outdoor lighting. I make a motion to approve the remaining Consent Agenda.

Commissioner Johnson: I'll second. All in favor?

Commissioner Saylor: Aye.

Commissioner Johnson: Aye. (Motion carried 2-0).

(Certified Claims in the amount of \$1,526,826.85 are located on Pages 24 through 27 of these Official Minutes)

(Non-Certified Claims in the amount of \$458.06 are located on Page 27 of these Official Minutes)

(Payroll is located on Pages 27 through 28 of these Official Minutes)

(Springbuk Contract is located on File in the Auditor's Office)

(Amendment for lighting is located on Pages 28 through 29 of these Official Minutes)

PANDEMIC REQUEST 21-61

Roger Emmons: Thank you. I would add that Heather took a request, Pandemic Relief Fund Request Form. It's (Request) 21-61 from the Health Department. Their Administrator, Aaron Franz submitted that. It's in the amount of twenty-two thousand five hundred ninety dollars (\$22,590.00). I talked to Councilman Richmond prior to the meeting and he stated now that everything is itemized and he's got all the information, he's OK with this. I don't know if Dan's had a chance to review it or not.

Commissioner Saylor: I've reviewed it, but Greg, Greg and I had spoke about it and he had a lot of questions. And he, he was gonna submit the email to Aaron. And, and I read that, but I have not spoke with Greg. So, he spoke with you. So, if Greg is good with it, then then I'm good with it.

Roger Emmons: And he told me he was.

Commissioner Saylor: Okay. Alright.

Roger Emmons: Yeah, Greg's in, correct, Greg? Yeah. So, you're okay with that?

Commissioner Saylor: If Mr. Richmond is, I'm good with it.

Roger Emmons: Yeah. I'd recommend a motion to approve (Request) 21-61 Pandemic Relief Fund Request.

Commissioner Saylor: I make a motion to approve Pandemic Relief 21-61.

Commissioner Johnson: I'll second. All in favor?

Commissioner Saylor: Aye.

Commissioner Johnson: Aye. (Motion carried 2-0).

Roger Emmons: Thank you, gentlemen. That's all I have.

(Pandemic Relief 21-61 is located on Pages 30 through 31 of these Official Minutes)

**COUNTY ACQUISITIONS
OPENING OF BIDS FOR COUNTY UNIFORMS**

Commissioner Johnson: County acquisitions. Mrs. Sievers, how are you this evening.

Sherrie Sievers: I am good, thank you.

Commissioner Saylor: You're doing a lot of work for so few a...

Commissioner Johnson: She is.

Roger Emmons: Thank you, Sherrie. So pursuant to Indiana Code 5-22-6 for services, we received the first bid for the Warrick County uniform contract. This is the second invitation to quote which was submitted on November 29th after all bids were tabled in the Commissioners' meeting on November 8th. And then it was denied on November 22nd. We received only one (1) bid from UniFirst Corporation which I have provided to the Commissioners on the bid register. I have also attached two (2) references for review along with the original invitations to quote from November the 8th. UniFirst Corporation is the County's current uniform provider we have asked the company to bid for a total of eight (8) uniforms. Five (5) at the County Highway Department, one (1) at the Sheriff's Department, and two (2) for our maintenance gentleman here. And I'm confident the Commissioners will select the quote that they feel is best and be in the best interest of Warrick County. Any questions gentlemen?

Commissioner Johnson: Got a lot to choose from here.

Roger Emmons: It is over four dollars (\$4.00) cheaper.

Commissioner Johnson: It is. I noticed that it had went down from the last quote. Bobby, these are mostly your guys. What do you want to do?

Bobby Howard: They want uniforms. If they want the uniforms, this is what they've got.

Commissioner Saylor: But, this is the one (1) who's doing it now?

Commissioner Johnson: Right.

Sherrie Sievers: Right.

Commissioner Saylor: I've had...

Commissioner Johnson: I've had some complaints.

Commissioner Saylor: I've had my ear bent, when the people are not happy. Bobby, what's your thoughts with it? Are those justified or legitimate concerns? Or...?

Bobby Howard: If there's a problem, usually, it can be worked out. So...

Commissioner Saylor: That individual had gotten it worked out?

Bobby Howard: Yeah.

Commissioner Saylor: Okay.

Bobby Howard: If they need my assistance or something, they can come to the office. Cause I don't find out about these issues until well after the fact.

Commissioner Saylor: Until they complain to a Commissioner about it.

Bobby Howard: Evidently.

Commissioner Johnson: Here's an option, and that is that we deny this one (1) bid and let the guys choose who they want to go through themselves.

Commissioner Saylor: And, and I ask about that, but the only thing is they're not going to get this pricing, correct?

Sherrie Sievers: That's correct.

Commissioner Johnson: What kind of pricing they gonna get?

Commissioner Saylor: I don't know. Do you have an idea, Sherrie?

Sherrie Sievers: No. But, I'll be happy to reach out and ask.

Commissioner Johnson: Well, you've done enough work on this, Sherrie.

Commissioner Saylor: Yeah, yeah, we're, guys...

Commissioner Johnson: You've got eight (8) individuals.

Commissioner Saylor: And is this is this one (1) year deal, Sherrie?

Sherrie Sievers: It's a three (3) year. It's hard to get anybody to do that little amount for only one (1) year because they've got so much cost involved. You know, they'll lose money on a one (1) year contract. So, three (3) years is the minimum.

Bobby Howard: Is there an annual increase included?

Sherrie Sievers: That I can't answer, Bobby, I'm sorry. But, UniFirst did come in at thirty-one-thirteen (\$31.13) per week. Previously Aramark came in at thirty-five-forty-two (\$35.42) per week and Cintas came in at thirty (\$30.00), you might as well say thirty-nine dollars (\$39.00) a week.

Commissioner Saylor: Counselor if, I mean, if Bobby gets a bunch of negative feedback, let's say six (6) months, a year into this, is there a way we can, we can get out of it? I mean if it's, if it's too, if he's not able to work things out, is there...?

Roger Emmons: Have they submitted a contract?

Bobby Howard: There's a contract that will be submitted and it's got some language in it in regards to that.

Commissioner Johnson: And we can amend it as necessary also.

Bobby Howard: Yes, beforehand.

Todd Glass: Depends on what the contract says.

Roger Emmons: It was either thirty (30) or sixty (60) day written notice of termination.

Commissioner Saylor: By either party?

Roger Emmons: Yes.

Bobby Howard: (Inaudible) ninety (90) days.

Commissioner Saylor: Well, I mean, but...

Todd Glass: You can terminate apparently, if Roger recollects.

Roger Emmons: I can find out pretty quickly but...

Commissioner Johnson: I don't care.

Commissioner Saylor: I make a motion to approve the lowest bid, or the only bid.

Commissioner Johnson: I'll second that. So, all in favor?

Commissioner Saylor: Aye.

Commissioner Johnson: Aye. (Motion carried 2-0).

Commissioner Saylor: Thank you. Sorry.

Commissioner Johnson: Thank you, Sherrie.

Sherrie Sievers: I'll reach out to UniFirst and get that contract and get it to you then, Todd, for your review. Thank you, Commissioners.

Commissioner Saylor: Thank you.

(UniFirst Contract is located on File in the Auditor's Office)

**COUNTY ATTORNEY
ESTABLISHING COUNTY COUNCIL DISTRICTS
ORDINANCE 2021-42 FIRST READING**

Commissioner Johnson: Next up we have our County Attorney.

Todd Glass: Thank you, Mr. President. First item on the agenda needing to be addressed is an Ordinance establishing boundaries for County Council Districts. That would be proposed Ordinance 2021-42...

Kristine Georges: '42.

Todd Glass: '42. And if I may just briefly mention to you that this is pursuant to Indiana Constitution and comes every ten (10) years after the census has been completed. And I have the proposed Ordinance that I'll hand to the two (2) of you.

Roger Emmons: Todd, do you want me to offer copies of the packages?

Todd Glass: Certainly, we also have handouts for anybody that would like to see them, which is the proposed Council Districts. Probably, if it's what you're passing out, Roger, it includes the existing current Council Districts 1, 2, 3, and 4 with the listed populations and population deviation percentages and the proposed Council Districts for 2021 and 2022 going forward with each Council District's Precincts listed. Mr. President, I know that I've been discussing with the Board these Council Districts and the compliance with the Indiana Constitution, that rule is that the population in each District needs to be equal. And the Indiana courts have interpreted equal to be within 10% of each other. Currently, the existing Council Districts have a population deviation of forty-five point two percent (45.2%) which is well beyond the Constitutional limits. The boundaries that you have in front of you that you have discussed and you are considering lists the three (3) Council District's population ranging between fifteen thousand four-seventy-eight (15,478) to the highest of sixteen thousand four-thirteen (16,413) with a deviation of only five point five percent (5.5%), a reduction of almost thirty-seven percent (37%) deviation.

Commissioner Saylor: You said three (3), but there are four (4) Districts. I don't get a chance to correct the Counsel very often so I...

Todd Glass: Alright, if I said three (3) Districts, I misspoke. I've got four (4) listed right in front of me. The Ordinance of the Board of Commissioners, Warrick County, Indiana, amending Chapter 131 of the Code of Ordinances lists the requirements for setting Council Districts and would amend Section 30.15 to list the correct Precincts in which the four (4) Districts are comprised. It would be effective January 3, 2022. All passed by the Board of Commissioners of Warrick County. This would most likely be approved today on First Reading since we will not be able to have a unanimous vote of the Board. And I'm happy to answer any questions. We have been in communication with the President of the Council, Mr. Richmond and Council Member Ron Bacon, liaison from the Council on this issue, describing the boundary changes. It certainly is an opportunity to adopt some boundaries that make a lot more sense than the current ones. Especially, I would personally, just from my own legal opinion, it seemed like City of Boonville and Ohio Township were quite chopped up. The way Chandler and the boundaries around Chandler have been existing, again, very chopped up. And the Board has discussed with me in looking at these boundary lines to just simply look at making the boundaries more sensical and looking at the population numbers and making them compliant with the Constitution. And if there are no other questions, you have Ordinance 2021-42 establishing County Council Districts ready for you to entertain a motion to approve on First Reading.

Commissioner Saylor: Any questions?

Commissioner Johnson: Nope.

Commissioner Saylor: I make a motion to approve Ordinance 2021-42 for the County Council Districts on First Reading.

Commissioner Johnson: And I'll second. All in favor?

Commissioner Saylor: Aye.

Commissioner Johnson: Aye. (Motion carried 2-0).

Todd Glass: Thank you, Mr. President. I'll see what we're looking at as far as a timeline to get the Second Reading approved and I'll advise you.

**ORDINANCE ESTABLISHING COUNTY COMMISSIONER DISTRICTS
ORDINANCE 2021-43 FIRST READING**

Todd Glass: Secondly, proposed Ordinance 2021-43 would be an Ordinance of the Board of County Commissioners of Warrick County, Indiana amending Chapter 131 of the Code of Ordinances of Warrick County establishing County Commissioner Districts. In looking at the County Commissioner Districts, you advised me to prepare an Ordinance not making any changes to those District lines. However, this Ordinance is required by the Constitution to be reviewed and passed by the Board of Commissioners, listing the applicable precincts that go into each of Commissioner District. Of course, you've changed some of these precincts, so these lists are updated and compliant with Constitution and ready for your vote and approval Ordinance 2021-43.

Commissioner Saylor: I make a motion to approve Ordinance 2021-43 is establishing the County Commissioner Districts.

Commissioner Johnson: And I'll second. All in favor?

Commissioner Saylor: Aye.

Commissioner Johnson: Aye. (Motion carries 2-0).

Todd Glass: Thank you, Mr. Vice President. Give me a moment. I've got two (2) Ordinances here for the Commissioners. Okay, I'm good. Sorry, Mr. Vice President. Too many pieces of paper.

APPROVAL OF ORDER ESTABLISHING PRECINCTS

Todd Glass: Next item on our agenda, Mr. Vice President, is Order Establishing Precincts. This Board is previously already approved the updates to the Precinct boundaries in Warrick County and prior meetings. This is just an Order Establishing Precincts stating that you have complied with those requirements and simply a requirement that you move and pass the Order Establishing Precincts so ordered this 13th day of December 2021.

Commissioner Saylor: Make a motion to approve the Order of Establishing Precincts for Warrick County.

Commissioner Johnson: I'll second. All in favor?

Auditor Stevens: Will you allow discussion on this? On (inaudible) Precincts?

Todd Glass: That's already been passed. This is an Order Establishing Precincts just documenting the prior approval by the Board of the Establishment of Precincts in conjunction with the Election Division. If you have any questions, Mrs. Stevens, I'll certainly be happy to talk with you about them. Did we get to a vote?

Commissioner Johnson: No. You made the motion?

Commissioner Saylor: To approve, yes.

Commissioner Johnson: I'll second. All in favor?

Commissioner Saylor: Aye.

Commissioner Johnson: Aye. (Motion carries).

Todd Glass: Thank you.

(Order Establishing Precincts is located on Page 31 of these Official Minutes)

**AMENDMENT TO INDEPENDENT CONTRACTOR AGREEMENT FOR WARRICK
COUNTY GRANTS DEVELOPMENT DIRECTOR**

Todd Glass: The next item on the agenda, the Amendment to Independent Contractor Agreement for Warrick County Grants Development Director. This Independent Contractor Agreement was previously entered into. This was just an amendment and clarification updating Exhibit A to the Independent Contractor Agreement detailing the services that the Warrick County Grants Development Director is to provide to the County. And it includes the services to administer supervised review and perform other (inaudible) services incidental to the Coronavirus State and Local Fiscal Recovery Fund received by Warrick County under the American Rescue Plan Act. And that just brings the Independent Contractor Agreement up to date and reflective of the Grants Development Director's role and duties.

Commissioner Johnson: Do you need anything, any motion?

Todd Glass: Yes, just a motion to approve that change to the Independent Contractor Agreement.

Commissioner Saylor: So moved.

Commissioner Johnson: Second. All in favor?

Commissioner Saylor: Aye.

Commissioner Johnson: Aye. (Motion carried 2-0).

Todd Glass: Thank you.

(Independent Contractor Amendment is located on File in the Auditor's Office)

**HSA COUNTY CONTRIBUTION POLICY
RESOLUTION 2021-18**

Todd Glass: Next is the Health Savings Account County Contribution Policy, I have a Resolution, a number, I'm sorry, Kristine?

Roger Emmons: That needs to be corrected to 2021. I show 2020 on my copy unless I got...

Todd Glass: Okay, we must have fixed that already, Roger.

Kristine Georges: The Resolution number would be 2021-18.

Roger Emmons: '18.

Todd Glass: This is a Resolution of the Board of Commissioners of Warrick County, Indiana, establishing a policy for contributions to County employees Health Savings Accounts, resolving by the Board of Commissioners that an eligible employee of Warrick County, if they elect to participate in the County's Health Insurance HSA Plan Option, regardless of the employees' health insurance coverage for the coverage period, then in that event Warrick County shall make the following contributions towards said employees' HSA plan on a quarterly basis. Employee only forty dollars and one cent (\$40.01) per quarter. Employee and spouse ninety-seven dollars (\$97.00) per quarter. Employee and children one hundred fifty-eight dollars and eight cents (\$158.08) per quarter. And the policy adopted this date, I presume, would be effective January 1st, I think. January 1st. And this would be added to the other Employment Policies for the County.

Commissioner Saylor: I make a motion to approve Resolution 2021-18 establishing the contributions to the County employees' Health Savings Account.

Commissioner Johnson: I'll second. All in favor?

Commissioner Saylor: Aye.

Commissioner Johnson: Aye. (Motion carried 2-0).

Todd Glass: Thank you, Mr. Vice President.

Commissioner Saylor: Now, that doesn't have to, that doesn't have to be, that's not First Reading. That's approved?

Todd Glass: That's good. That's a Resolution approved 2 to 0 (2-0).

Commissioner Saylor: Okay.

(Resolution 2021-18 is located on Page 32 of these Official Minutes)

WILSON FAMILY PRACTICE CONTRACT

Todd Glass: I don't believe I have everything, Roger can correct me if I'm wrong. But, we have a contract with Wilson Family Practice for the provision of services for Warrick County. My understanding is that we're still working on that. Is that correct?

Roger Emmons: That's correct. And Heather has confirmed that.

Todd Glass: So, I would ask the Commissioners to simply table that, I believe, to your next meeting.

Commissioner Saylor: Make a motion to table the Wilson Family Practice Contract to our next meeting of December 27th.

Commissioner Johnson: And I'll second. All in favor?

Commissioner Saylor: Aye.

Commissioner Johnson: Aye. (Motion carried 2-0).

JOB QUOTES FROM RALPH SIMPSON

Todd Glass: Lastly, Mr. Vice President, just to do a housekeeping matter, I believe we have, Sherrie has been receiving the quotes, smaller job quotes from Ralph Simpson Services, and seeking invitations to bid for those services including some repair work in the Old Courthouse and she's been having difficulty obtaining the three (3) quotes. In order to proceed with those projects, the small projects that they are, we have a one (1) job quote for, Sherrie can maybe help me with this a little bit. But, one (1) is I believe the Grants Development Director's Office. And more recently a second quote again under the same circumstances for additional work, I believe, in the Health Department.

Sherrie Sievers: Yes, I don't believe the Health Department's up there, but I think that other quote we have is for the break room, if I'm not mistaken.

Commissioner Saylor: Yeah and, and I've talked to Commissioner Phillippe about that. We're probably gonna, we're probably gonna revisit that. I think we're, we're gonna re...we might not go as extensive with that.

Sherrie Sievers: Okay.

Todd Glass: Regarding the work in the Grant's Development Director's Office? That is, even though that work has been initiated, that's a contract you should approve under Section 31.08 of the County Ordinances, Section E under Services, which you haven't done yet.

Commissioner Saylor: So, we need to approve it for the, for the grant writers?

Todd Glass: Correct. Correct.

Commissioner Saylor: So, I make a motion to, hang on, Bob. Yeah, I'll make a motion to approve that. Have you been down there and seen it?

Commissioner Johnson: Go ahead, Dan.

Commissioner Saylor: I'll make a motion to approve that, what would it be, would be a policy, Todd, or...?

Todd Glass: Just approved the quoted services under 31.08 E of the Ordinances.

Commissioner Saylor: So moved.

Commissioner Johnson: I'll second. All in favor?

Commissioner Saylor: Aye.

Commissioner Johnson: Aye. (Motion carried 2-0).

Commissioner Saylor: Thank you.

Todd Glass: Thank you, Commissioner Johnson.

Commissioner Johnson: You're welcome, Sir.

(Ralph Simpson Quote is located on Page 32 of these Official Minutes)

**COUNTY ENGINEER/HIGHWAY DEPARTMENT
DISTRICT 1 HIGHWAY FACILITY BID OPENING**

Commissioner Johnson: Next up we have Highway Engineer, Bobby.

Bobby Howard: Thank you. First item I have is the bid openings of the District 1 Highway/Storm Water facility. We received five (5) sealed bids. Did you, I think there's bid tabs maybe up here. Is there a bid tab form that you (inaudible)...?

Commissioner Saylor: Is everybody got a copy of that?

Todd Glass: Oh, yes. Yeah, pass those out.

Bobby Howard: Jason's here with Lamar.

Todd Glass: Jason, yes.

Commissioner Saylor: Okay.

Roger Emmons: Oh, okay.

Commissioner Saylor: You guys, you guys wanna copy of it?

Bobby Howard: Do you have any other copies? Give Roger one (1). (Inaudible) write it down.

Roger Emmons: Thank you. Anybody else up here need one? Todd? No?

Bobby Howard: First one (1) I have is Danco Construction.

Commissioner Saylor: Bobby's got his Ginsu knife.

Todd Glass: Um hum.

Bobby Howard: The certification and base bid is one million seven hundred forty-five thousand dollars (\$1,745,000.00).

Roger Emmons: One million seven-forty-five (\$1,745,000.00).

Bobby Howard: And then if we go with the aluminized steel fencing, it's a deduction of three thousand dollars (\$3,000.00).

Commissioner Saylor: It's a deduction? Verses the coated? The black coated?

Bobby Howard: Yes. Yes.

Commissioner Saylor: Wow. Interesting.

Bobby Howard: Next one (1) I have is from, need to sharpen my Ginsu knife.

Roger Emmons: Don't cut yourself, Bobby.

Commissioner Saylor: Cut yourself, I'm worried about somebody getting fileted.

Kristine Georges: I must admit I've been eyeing that darn thing all meeting.

Bobby Howard: Again, this one (1) is Arc Construction.

Commissioner Johnson: Who is it?

Bobby Howard: Arc Construction. One million nine hundred fifty-three thousand one hundred dollars (\$1,953,100.00). And the galvanized, or the aluminized steel fencing is a deduction of nine thousand four hundred sixty dollars (\$9,460.00). This one is from Ragle, Incorporated. And this one (1) is for two million two hundred thousand (\$2,200,000.00). And the aluminized fencing is a deduction of nine thousand four hundred sixty-three dollars (\$9,463.00). Two million two hundred thousand (\$2,200,000.00).

Todd Glass: Correct.

Bobby Howard: Next one (1) is KM Construction Services.

Commissioner Saylor: Where they out of, Bobby?

Bobby Howard: Evansville.

Commissioner Saylor: Evansville?

Bobby Howard: County Line Road. Two million twenty thousand dollars (\$2,020,000.00). And it is a deduction of (\$5,000.00) for the fencing steel. And the last bid is Empire Contractors. And this bid for Empire Contractors is one million eight hundred forty-four thousand dollars (\$1,844,000.00). One million eight hundred forty-four thousand (\$1,844,000.00). And subtract, looks like a deduct of ten thousand dollars (\$10,000.00). I just recommend we take the bids under advisement for review.

Todd Glass: For responsible bidder and responsiveness.

Commissioner Saylor: I make a motion to take the five (5) bids that were receive under advisement.

Commissioner Johnson: I'll second. All in favor?

Commissioner Saylor: Aye.

Commissioner Johnson: Aye. (Motion carried 2-0).

BELL ROAD CHANGE ORDER 14

Bobby Howard: The last item I have here is Change Order 14 for Bell Road. This is for line removal for five hundred twenty-five dollars (\$525.00).

Commissioner Saylor: What, Bobby, that was line removal?

Bobby Howard: Yes. This was due to some of the existing lanes that we tied into. The new striping didn't line up with those lanes and it wasn't in the plan to remove the old line if, it was overlooked. So, this is five hundred twenty-five dollars (\$525.00).

Commissioner Saylor: Make a motion to approve the Change Order 14.

Commissioner Johnson: I reluctantly second. All in favor?

Commissioner Saylor: Aye.

Commissioner Johnson: Aye. (Motion carries 2-0).

Bobby Howard: That is all I have, thank you.

Commissioner Johnson: I lost my agenda. Alright. Roger, anything?

Roger Emmons: No, Sir.

(Bell Road Change Order 14 is located on File in the Auditor's Office)

COMMISSIONER ITEMS FOR DISCUSSION OUTDOOR LIGHTING PROJECT FOR THE JC

Commissioner Johnson: Commissioner Saylor, do you have anything to add?

Commissioner Saylor: I've got a couple things one (1), just, just for, make sure people know the Outdoor Lighting Project is behind the JC. Those original lights, if you noticed that. We have put in a retaining wall to fix some drainage issues there that that plague us not only all spring, but all winter long. Whenever we get a rain, it pools down there. So, I think we've got that issue that fixed and addressed. We've made a little area out there for the employees where they can sit, you know, for lunch time or break time which is nice. Sherrie's been doing a lot of work on getting bids and quotes for our canopy replacement. So, Sherrie, thank you for that. I think the project's looking great so far, and just a nice addition and the lighting will be a nice addition.

PRAYERS FOR THE VICTIMS IN THE KENTUCKY WEATHER DISASTER

Commissioner Saylor: The other thing I just wanna ask is, you know, we keep our friends to the south of us in thoughts and prayers. That was, I, I followed that to that event from the start up. And, and that was, well, I saw first-hand, destruction of the hurricane in Florida here a few years ago or a couple years ago. But, that's some major, major damage and I just hope when people build big buildings that they build safe areas in them where employees can go. I, I think that's something that we need to look at as Commissioners to put in into our building code. That we require safe areas in big buildings. Cause they're just build this trans steel building. By the way, that, the building quote that you, that we're doing, Bobby has a...

Bobby Howard: Yeah, reinforced walls and concrete slab.

Commissioner Saylor: Reinforced room in it. That's in case of this, we've, we've had several tornadoes go through that area. And that's in case, that's for one (1) reason and one (1) reason only, to protect employees in case something is bearing down on them. So anyway. That's all I have, Bob.

Commissioner Johnson: Okay.

Roger Emmons: I do have a comment.

Commissioner Johnson: Yes, Sir.

COMMISSIONERS RECOGNIZED FOR OUTSTANDING TEAM EFFORT

Roger Emmons: I'd like to announce to everybody, if you don't know, that at the recent Annual Indiana Association of County Commissioners Conference, this Board received the award for outstanding team effort for Board of County Commission, Commissioners based on two (2) projects. One (1) is this Courthouse Renovation Project which is really created a wonderful centerpiece for the County seat of Warrick County. And secondly, for their insight into getting a Comprehensive Capital Improvement Plan and Program which was done by a local consultant. So, congratulations Commissioners, it's well deserved.

Commissioner Johnson: Thank you.

Commissioner Saylor: Well, now that Roger said that, I gotta add something to it. You know, while the Commissioners got recognition for that, you know, there were several other people, you know, that that probably or not probably, they were behind the scenes that, that made it happen. And of course from our Legal Counsel to Roger was involved in almost every meeting of it. Brad Downing, our Head of Maintenance. And our Building Inspector, Dennis Lockhart. You know, those guys don't get the recognition, you know, that maybe we got. But, however, they deserve the recognition because, you know, when you have, we didn't have, we didn't, our taxpayers were not charged, you know, a hundred thousand dollars (\$100,000.00) to have a project, you know, owner's rep or supervisor on, on site every day. We, we did that by having six (6) to (8) eight sets of eyes on those guys every day and I think, I think if the truth be known, they're glad the projects over. While, they think it's a good project, I know be before Commissioner Johnson agreed to sign the contract he wanted a couple hundred thousand dollars (\$100,000.00) worth of items thrown into it. They basically did that. And so, we squeezed them pretty hard. But, I think ultimately, we got a good project done for the taxpayers of this County, and, and we continue to get compliments on a daily basis. But ultimately, I think it is a great team effort and I think Roger and everybody who was involved in it from our office staff to, I mean, even Bobby and Steve, you know, helped on some of the things so...

Roger Emmons: And to Council appropriating, getting the bond in place.

Commissioner Saylor: I guess we got it...

Roger Emmons: Even though we wanted more money. It turned out really nice.

Commissioner Saylor: So, thank you.

Roger Emmons: Thank you, guys.

Commissioner Johnson: And I agree with that and I also wanted to, you know, I'd touch on, please remember our folks, I think all of us probably know somebody that's been hit by this extreme damage that was done this weekend. So, please keep everybody in your prayers. And, you know, that could have very easily hit us as well. So keep that in mind. Thank you.

Commissioner Saylor: I make a motion to adjourn.

Commissioner Johnson: Second. All in favor?

Commissioner Saylor: Aye.

Commissioner Johnson: Aye. (Motion carried 2-0).

ADJOURNMENT: Meeting adjourned at 5:01 P.M.

WARRICK COUNTY BOARD OF COMMISSIONERS

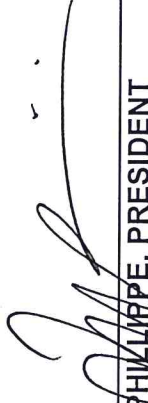
TERRY PHILIPPE, PRESIDENT

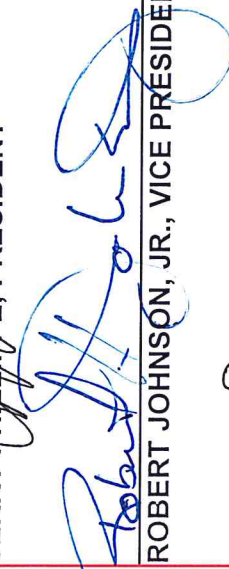
ROBERT JOHNSON, JR., VICE PRESIDENT

DAN SAYLOR, MEMBER

ATTEST:

DEBORAH K. STEVENS, AUDITOR
WARRICK COUNTY, INDIANA



Minutes transcribed by Kristine Georges

WARRICK COUNTY COMMISSIONERS ORDINANCE NO. 2021- 038
AN ORDINANCE TO AMEND ARTICLE XII(B) PLANNED UNIT DEVELOPMENT (PUD) SECTION 2. GENERAL REQUIREMENTS SUBSECTION (A) PERMITTED USES IN PUD DISTRICT OF THE COMPREHENSIVE ZONING ORDINANCE IN EFFECT FOR WARRICK COUNTY, INDIANA

BE IT ORDAINED BY THE BOARD OF COUNTY COMMISSIONERS OF WARRICK COUNTY, INDIANA, as follows to wit:

- Section 1. That article XII(B) Section 2 Subsection A be amended to read as follows:
 - A. Permitted uses in PUD District A PUD may be utilized in any of the following zoning districts.
CON, A, R-1, R-1A, R-1B, R-1C, R-1D, R-2, R-2A, R-2B, R-3, R-0, C-1, C-2, C-3, C-4
- Section 2. This Ordinance shall be in full force and effect from and after its passage by the Board of County Commissioners for Warrick County, State of Indiana.

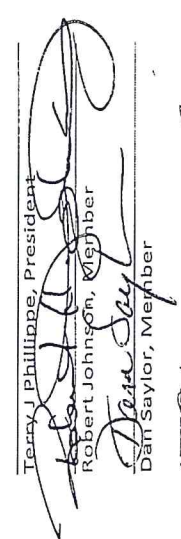
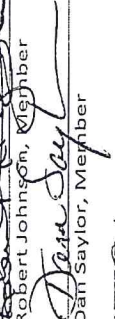
Approved this 13th day of December, 2021.

Terry J. Philippe, President

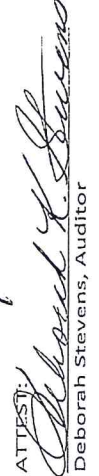
Robert Johnson, Member

Dan Saylor, Member

ATTEST:

Deborah Stevens, Auditor

WARRICK COUNTY, INDIANA
Board of County Commissioners
Court House
Boonville, IN 47601

FILED
NOV 30 2021
WARRICK COUNTY CLERK

Certificate of Compliance - Deer Creek
Plan and Specifications - Street Construction

Submission Date: November 29, 2021
 Probable Start Construction: December 2021
 Probable Finish Construction: December 2026
 Project Location: Property located on the east side of Stevenson Station Road southeast of the intersection formed by Ayrshire Road and Stevenson Station Road.
 Describe in detail type of street construction:
 No new streets will be constructed.
 All storm sewers shall be Reinforced Concrete Pipe (RCP) as specified in the construction plans.
 Lawn area within the roadway right-of-way and all drainage ditches and swales to be seeded.
 TOTAL Streets - \$0
 TOTAL Signs - \$0
 TOTAL Miscellaneous - \$0
 TOTAL Storm Sewer - See attached engineer cost estimate \$0
 TOTAL Sidewalks - \$0

I, the Owner of the above named subdivision certify that the information given above is correct, that all information has been prepared accordingly and in compliance with the plans and specifications as submitted and attached hereto.

Owner name: Kurt Phillips - KSKS Development, LLC
 Address: P.O. Box 191, Boonville, IN 47601

I certify that to the best of my knowledge and belief:

That these plans and specifications for this subdivision are in compliance with the standards for road and street construction as set forth in the subdivision Control Ordinances for Warrick County, Indiana.

That the plans and specifications as presented and attached hereto are under my dominion and control and were created by me and my employees.

Signature: [Signature]

Typed Name: James E. Madix
 Engineer: X Licensed Land Surveyor
 Address: 4800 Rosebud Lane, Newburgh, IN 47630



Ind. Reg. No. 10100250
 Phone No. 812-464-9585
 SEAL

I will perform reasonable and periodic inspection of this project during construction to determine that such construction is in accordance with the plans and specifications for this project as filed by the Board of County Commissioners, Warrick County, Indiana, and attached hereto.

Signature: [Signature]

Typed Name: James E. Madix
 Engineer: X Licensed Land Surveyor
 Address: 4800 Rosebud Lane, Newburgh, IN 47630



Ind. Reg. No. 10100250
 Phone No. 812-464-9585
 SEAL

Reviewed By: Area Plan Commission

Date: _____ Comments _____

Reviewed By: County Engineer

By: _____

Date: _____ Comments _____

FILED
NOV 30 2021
WARRICK COUNTY CLERK

Approval granted by the Board of County Commissioners this 13 day of DECEMBER, 2021.

President
Member
Member
[Signature]
[Signature]
[Signature]

Attest:
[Signature]
County Auditor

Additional Space for Comments:

Four (4) Copies of the Certificate of Compliance accompanied by four (4) copies of the plans shall be filed with the Board of County Commissioners for approval. Approved copies shall be filed with the offices of the Area Plan Commission and the County Engineer. One Copy shall be retained by the Licensed Land Surveyor or Engineer and the property owner shall receive a copy.

WARRICK COUNTY, INDIANA
Board of County Commissioners
Court House
Boonville, IN 47601

**Certificate of Compliance – High Pointe Centre North Section 5 PUD
Plan and Specifications - Street Construction**

Submission Date: November 1, 2021
Probable Start Construction: January 2022
Probable Finish Construction: January 2023
Project Location: Property located on the North Side of High Pointe Drive, Newburgh, IN 47630, a distance of 0 feet northeast of the intersection of High Pointe Drive and Bell Road.

Describe in detail type of street construction:

No new streets will be constructed.

All storm sewers shall be High Density Polyethylene (HDPE).

All earthwork shall be compacted to 95% standard proctor.

Lawn area within the roadway right-of-way and all drainage ditches and swales to be seeded.

| | |
|---------------------|---------|
| TOTAL Streets | \$ 0.00 |
| TOTAL Signs | \$ 0.00 |
| TOTAL Miscellaneous | \$ 0.00 |
| TOTAL Storm Sewer | \$ 0.00 |
| TOTAL Sidewalks | \$ 0.00 |
| TOTAL | \$ 0.00 |

FILED
NOV 04 2021
WARRICK COUNTY
AREA PLAN COMMISSION

J:\6000\6000-5096\5093\CIVIL 3D\Documents\HPCN\6093-5 Certificate of Compliance.docx

Page 1

Reviewed By: Area Plan Commission

Date: _____ Comments: _____

Reviewed By: County Engineer

Date: _____ Comments: _____

Approval granted by the Board of County Commissioners this 13 day of DECEMBER, 2021.

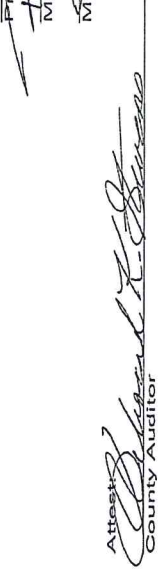
Attest: 
County Auditor

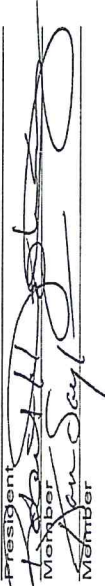
President
Member
Member

Additional Space for Comments:

Four (4) Copies of the Certificate of Compliance accompanied by four (4) copies of the plans and specifications for street construction shall be submitted to the Board of County Commissioners for approval. Approved copies shall be filed with the offices of the Area Plan Commission and the County Engineer. One Copy shall be retained by the Licensed Land Surveyor or Engineer and the property owner shall receive a copy.

FILED
NOV 04 2021
WARRICK COUNTY
AREA PLAN COMMISSION

J:\6000\6000-5096\5093\CIVIL 3D\Documents\HPCN\6093-5 Certificate of Compliance.docx

Page 3



November 1, 2021
Warrick County Drainage Board
Attention: Phil Baxter
107 W. Locust Street, Suite 206
Boonville, IN 47601

Re: No Drainage Improvements Request Letter
High Pointe Centre North Section 5 PUD
Morley Project #828.1.001-A

Dear Phil:

On behalf of Ortiz Ayala, LLC we ask that this project require no drainage improvements. The project will utilize the existing drainage system designed and constructed for High Pointe Centre North. All of the drainage for High Pointe Centre North Section 5 PUD was included in the overall drainage plan for High Pointe Centre North.

If you have any questions, comments, or require additional information, please contact our office at (812) 484-9585.

Sincerely,

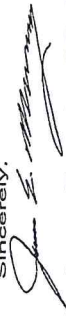

James E. Morley, PE, PS
President
Encl: Primary Plat

cc: File





J:\6000\6000-5096\5093\CIVIL 3D\Documents\HPCN\6093-5 No Drainage Improvements Letter.docx

FILED
NOV 04 2021
WARRICK COUNTY
AREA PLAN COMMISSION

WARRICK COUNTY COMMISSIONERS ORDINANCE NO. 2021- 038
AN ORDINANCE TO AMEND ARTICLE XII(B) PLANNED UNIT DEVELOPMENT (PUD) SECTION 2 GENERAL REQUIREMENTS SUBSECTION (A) PERMITTED USES IN PUD DISTRICT OF THE COMPREHENSIVE ZONING ORDINANCE IN EFFECT FOR WARRICK COUNTY, INDIANA

BE IT ORDAINED BY THE BOARD OF COUNTY COMMISSIONERS OF WARRICK COUNTY, INDIANA, as follows to wit:

Section 1. That article XII(B) Section 2 Subsection A be amended to read as follows:

A. Permitted uses in PUD District. A PUD may be utilized in any of the following zoning districts.

CON, A, R-1, R-1A, R-1B, R-1C, R-1D, R-2, R-2A, R-2B, R-3, R-O, C-1, C-2, C-3, C-4

Section 2. This Ordinance shall be in full force and effect from and after its passage by the Board of County Commissioners for Warrick County, State of Indiana.

Approved this 13th day of December, 2021.

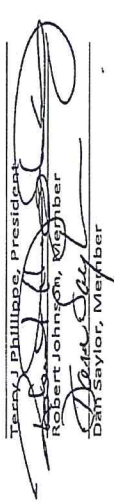
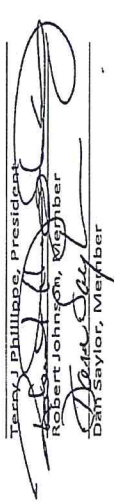
Terry J. Philippe, President

Robert Johnson, Member

ATTEST:

Dan Saylor, Member

Public Hearing held by Area Plan Commission November 8, 2021.

Deborah Stevens, Auditor

WARRICK COUNTY COMMISSIONERS ORDINANCE NO. 2021- 39
AN ORDINANCE TO AMEND ARTICLE VII RECREATION AND CONSERVANCY "CON" DISTRICT SECTION 1 USE REGULATIONS OF THE COMPREHENSIVE ZONING ORDINANCE IN EFFECT FOR WARRICK COUNTY, INDIANA

BE IT ORDAINED BY THE BOARD OF COUNTY COMMISSIONERS OF WARRICK COUNTY, INDIANA, as follows to wit:

Section 1. That article VII Section 1 be amended to read as follows:

No building or structure, or part thereof, shall be erected, altered or used, or land or water used, in whole or in part, for either than one or more of the following specified permitted uses:

(1.1) Single family residential Planned Unit Development (PUD) as provided for in Article XII (C).

Section 2. This Ordinance shall be in full force and effect from and after its passage by the Board of County Commissioners for Warrick County, State of Indiana.

Approved this 13th day of December, 2021.

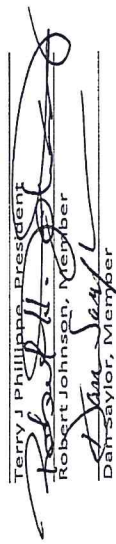
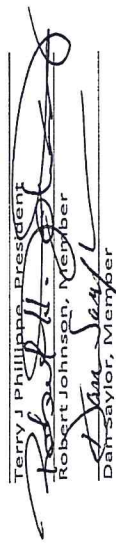
Terry J. Philippe, President

Robert Johnson, Member

ATTEST:

Dan Saylor, Member

Public Hearing held by Area Plan Commission November 8, 2021.

Deborah Stevens, Auditor

WARRICK COUNTY COMMISSIONERS ORDINANCE NO. 2021- 40
AN ORDINANCE TO AMEND ARTICLE VIII AGRICULTURAL "A" DISTRICT SECTION 1 USE REGULATIONS OF THE COMPREHENSIVE ZONING ORDINANCE IN EFFECT FOR WARRICK COUNTY, INDIANA

BE IT ORDAINED BY THE BOARD OF COUNTY COMMISSIONERS OF WARRICK COUNTY, INDIANA, as follows to wit:

Section 1. That article VIII Section 1 be amended to read as follows:

No building or structure, or part thereof, shall be erected, altered or used, or land or water used, in whole or in part, for either than one or more of the following specified permitted uses:

(1.0) Single family residential Planned Unit Development (PUD) as provided for in Article XII (C).

Section 2. This Ordinance shall be in full force and effect from and after its passage by the Board of County Commissioners for Warrick County, State of Indiana.

Approved this 13 day of December, 2021.

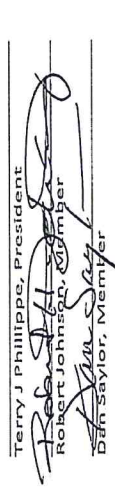
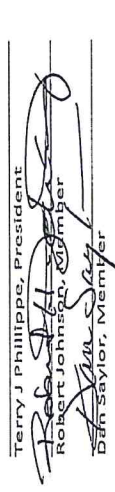
Terry J. Philippe, President

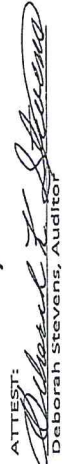
Robert Johnson, Member

ATTEST:

Dan Saylor, Member

Public Hearing held by Area Plan Commission November 8, 2021.

Deborah Stevens, Auditor



WARRICK COUNTY COMMISSIONERS ORDINANCE NO. 2021-41
 AN ORDINANCE TO AMEND ARTICLE XII (B) PLANNED UNIT DEVELOPMENT (PUD) SECTION 8
 SUBMISSION OF SUBDIVISION PLAT SUBSECTION C. RECORDING OF FINAL PLAT FOR THE
 COMPREHENSIVE ZONING ORDINANCE IN EFFECT FOR WARRICK COUNTY, INDIANA

BE IT ORDAINED BY THE BOARD OF COUNTY COMMISSIONERS OF WARRICK COUNTY, INDIANA, as follows
 to wit:

Section 1. That article XII (B) Section 8 Subsection C be amended to read as follows:
 The final plat must be recorded within three (3) years from the date of approval. If not recorded within
 this time limit, that plat shall be considered null and void.

Section 2. This Ordinance shall be in full force and effect from and after its passage by the Board of
 County Commissioners for Warrick County, State of Indiana.

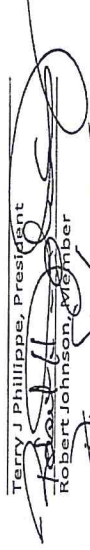
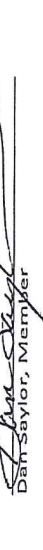
Approved this 13 day of December, 2021.

Terry J. Phillippe, President

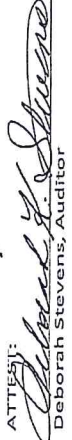
 Robert Johnson, Member

 Dan Saylor, Member

ATTEST:

 Deborah Stevens, Auditor

Public Hearing held by Area Plan Commission November 8, 2021.

| Effective Date | Project Name | Parcel ID | Area | Area Owner | Map Name | Amendment Class |
|----------------|------------------|-----------|------|----------------|--------------|---------------------|
| 12/13/2021 | Project Name 1 | 1100 | 1100 | Area Owner 1 | Map Name 1 | Amendment Class 1 |
| 12/13/2021 | Project Name 2 | 1100 | 1100 | Area Owner 2 | Map Name 2 | Amendment Class 2 |
| 12/13/2021 | Project Name 3 | 1100 | 1100 | Area Owner 3 | Map Name 3 | Amendment Class 3 |
| 12/13/2021 | Project Name 4 | 1100 | 1100 | Area Owner 4 | Map Name 4 | Amendment Class 4 |
| 12/13/2021 | Project Name 5 | 1100 | 1100 | Area Owner 5 | Map Name 5 | Amendment Class 5 |
| 12/13/2021 | Project Name 6 | 1100 | 1100 | Area Owner 6 | Map Name 6 | Amendment Class 6 |
| 12/13/2021 | Project Name 7 | 1100 | 1100 | Area Owner 7 | Map Name 7 | Amendment Class 7 |
| 12/13/2021 | Project Name 8 | 1100 | 1100 | Area Owner 8 | Map Name 8 | Amendment Class 8 |
| 12/13/2021 | Project Name 9 | 1100 | 1100 | Area Owner 9 | Map Name 9 | Amendment Class 9 |
| 12/13/2021 | Project Name 10 | 1100 | 1100 | Area Owner 10 | Map Name 10 | Amendment Class 10 |
| 12/13/2021 | Project Name 11 | 1100 | 1100 | Area Owner 11 | Map Name 11 | Amendment Class 11 |
| 12/13/2021 | Project Name 12 | 1100 | 1100 | Area Owner 12 | Map Name 12 | Amendment Class 12 |
| 12/13/2021 | Project Name 13 | 1100 | 1100 | Area Owner 13 | Map Name 13 | Amendment Class 13 |
| 12/13/2021 | Project Name 14 | 1100 | 1100 | Area Owner 14 | Map Name 14 | Amendment Class 14 |
| 12/13/2021 | Project Name 15 | 1100 | 1100 | Area Owner 15 | Map Name 15 | Amendment Class 15 |
| 12/13/2021 | Project Name 16 | 1100 | 1100 | Area Owner 16 | Map Name 16 | Amendment Class 16 |
| 12/13/2021 | Project Name 17 | 1100 | 1100 | Area Owner 17 | Map Name 17 | Amendment Class 17 |
| 12/13/2021 | Project Name 18 | 1100 | 1100 | Area Owner 18 | Map Name 18 | Amendment Class 18 |
| 12/13/2021 | Project Name 19 | 1100 | 1100 | Area Owner 19 | Map Name 19 | Amendment Class 19 |
| 12/13/2021 | Project Name 20 | 1100 | 1100 | Area Owner 20 | Map Name 20 | Amendment Class 20 |
| 12/13/2021 | Project Name 21 | 1100 | 1100 | Area Owner 21 | Map Name 21 | Amendment Class 21 |
| 12/13/2021 | Project Name 22 | 1100 | 1100 | Area Owner 22 | Map Name 22 | Amendment Class 22 |
| 12/13/2021 | Project Name 23 | 1100 | 1100 | Area Owner 23 | Map Name 23 | Amendment Class 23 |
| 12/13/2021 | Project Name 24 | 1100 | 1100 | Area Owner 24 | Map Name 24 | Amendment Class 24 |
| 12/13/2021 | Project Name 25 | 1100 | 1100 | Area Owner 25 | Map Name 25 | Amendment Class 25 |
| 12/13/2021 | Project Name 26 | 1100 | 1100 | Area Owner 26 | Map Name 26 | Amendment Class 26 |
| 12/13/2021 | Project Name 27 | 1100 | 1100 | Area Owner 27 | Map Name 27 | Amendment Class 27 |
| 12/13/2021 | Project Name 28 | 1100 | 1100 | Area Owner 28 | Map Name 28 | Amendment Class 28 |
| 12/13/2021 | Project Name 29 | 1100 | 1100 | Area Owner 29 | Map Name 29 | Amendment Class 29 |
| 12/13/2021 | Project Name 30 | 1100 | 1100 | Area Owner 30 | Map Name 30 | Amendment Class 30 |
| 12/13/2021 | Project Name 31 | 1100 | 1100 | Area Owner 31 | Map Name 31 | Amendment Class 31 |
| 12/13/2021 | Project Name 32 | 1100 | 1100 | Area Owner 32 | Map Name 32 | Amendment Class 32 |
| 12/13/2021 | Project Name 33 | 1100 | 1100 | Area Owner 33 | Map Name 33 | Amendment Class 33 |
| 12/13/2021 | Project Name 34 | 1100 | 1100 | Area Owner 34 | Map Name 34 | Amendment Class 34 |
| 12/13/2021 | Project Name 35 | 1100 | 1100 | Area Owner 35 | Map Name 35 | Amendment Class 35 |
| 12/13/2021 | Project Name 36 | 1100 | 1100 | Area Owner 36 | Map Name 36 | Amendment Class 36 |
| 12/13/2021 | Project Name 37 | 1100 | 1100 | Area Owner 37 | Map Name 37 | Amendment Class 37 |
| 12/13/2021 | Project Name 38 | 1100 | 1100 | Area Owner 38 | Map Name 38 | Amendment Class 38 |
| 12/13/2021 | Project Name 39 | 1100 | 1100 | Area Owner 39 | Map Name 39 | Amendment Class 39 |
| 12/13/2021 | Project Name 40 | 1100 | 1100 | Area Owner 40 | Map Name 40 | Amendment Class 40 |
| 12/13/2021 | Project Name 41 | 1100 | 1100 | Area Owner 41 | Map Name 41 | Amendment Class 41 |
| 12/13/2021 | Project Name 42 | 1100 | 1100 | Area Owner 42 | Map Name 42 | Amendment Class 42 |
| 12/13/2021 | Project Name 43 | 1100 | 1100 | Area Owner 43 | Map Name 43 | Amendment Class 43 |
| 12/13/2021 | Project Name 44 | 1100 | 1100 | Area Owner 44 | Map Name 44 | Amendment Class 44 |
| 12/13/2021 | Project Name 45 | 1100 | 1100 | Area Owner 45 | Map Name 45 | Amendment Class 45 |
| 12/13/2021 | Project Name 46 | 1100 | 1100 | Area Owner 46 | Map Name 46 | Amendment Class 46 |
| 12/13/2021 | Project Name 47 | 1100 | 1100 | Area Owner 47 | Map Name 47 | Amendment Class 47 |
| 12/13/2021 | Project Name 48 | 1100 | 1100 | Area Owner 48 | Map Name 48 | Amendment Class 48 |
| 12/13/2021 | Project Name 49 | 1100 | 1100 | Area Owner 49 | Map Name 49 | Amendment Class 49 |
| 12/13/2021 | Project Name 50 | 1100 | 1100 | Area Owner 50 | Map Name 50 | Amendment Class 50 |
| 12/13/2021 | Project Name 51 | 1100 | 1100 | Area Owner 51 | Map Name 51 | Amendment Class 51 |
| 12/13/2021 | Project Name 52 | 1100 | 1100 | Area Owner 52 | Map Name 52 | Amendment Class 52 |
| 12/13/2021 | Project Name 53 | 1100 | 1100 | Area Owner 53 | Map Name 53 | Amendment Class 53 |
| 12/13/2021 | Project Name 54 | 1100 | 1100 | Area Owner 54 | Map Name 54 | Amendment Class 54 |
| 12/13/2021 | Project Name 55 | 1100 | 1100 | Area Owner 55 | Map Name 55 | Amendment Class 55 |
| 12/13/2021 | Project Name 56 | 1100 | 1100 | Area Owner 56 | Map Name 56 | Amendment Class 56 |
| 12/13/2021 | Project Name 57 | 1100 | 1100 | Area Owner 57 | Map Name 57 | Amendment Class 57 |
| 12/13/2021 | Project Name 58 | 1100 | 1100 | Area Owner 58 | Map Name 58 | Amendment Class 58 |
| 12/13/2021 | Project Name 59 | 1100 | 1100 | Area Owner 59 | Map Name 59 | Amendment Class 59 |
| 12/13/2021 | Project Name 60 | 1100 | 1100 | Area Owner 60 | Map Name 60 | Amendment Class 60 |
| 12/13/2021 | Project Name 61 | 1100 | 1100 | Area Owner 61 | Map Name 61 | Amendment Class 61 |
| 12/13/2021 | Project Name 62 | 1100 | 1100 | Area Owner 62 | Map Name 62 | Amendment Class 62 |
| 12/13/2021 | Project Name 63 | 1100 | 1100 | Area Owner 63 | Map Name 63 | Amendment Class 63 |
| 12/13/2021 | Project Name 64 | 1100 | 1100 | Area Owner 64 | Map Name 64 | Amendment Class 64 |
| 12/13/2021 | Project Name 65 | 1100 | 1100 | Area Owner 65 | Map Name 65 | Amendment Class 65 |
| 12/13/2021 | Project Name 66 | 1100 | 1100 | Area Owner 66 | Map Name 66 | Amendment Class 66 |
| 12/13/2021 | Project Name 67 | 1100 | 1100 | Area Owner 67 | Map Name 67 | Amendment Class 67 |
| 12/13/2021 | Project Name 68 | 1100 | 1100 | Area Owner 68 | Map Name 68 | Amendment Class 68 |
| 12/13/2021 | Project Name 69 | 1100 | 1100 | Area Owner 69 | Map Name 69 | Amendment Class 69 |
| 12/13/2021 | Project Name 70 | 1100 | 1100 | Area Owner 70 | Map Name 70 | Amendment Class 70 |
| 12/13/2021 | Project Name 71 | 1100 | 1100 | Area Owner 71 | Map Name 71 | Amendment Class 71 |
| 12/13/2021 | Project Name 72 | 1100 | 1100 | Area Owner 72 | Map Name 72 | Amendment Class 72 |
| 12/13/2021 | Project Name 73 | 1100 | 1100 | Area Owner 73 | Map Name 73 | Amendment Class 73 |
| 12/13/2021 | Project Name 74 | 1100 | 1100 | Area Owner 74 | Map Name 74 | Amendment Class 74 |
| 12/13/2021 | Project Name 75 | 1100 | 1100 | Area Owner 75 | Map Name 75 | Amendment Class 75 |
| 12/13/2021 | Project Name 76 | 1100 | 1100 | Area Owner 76 | Map Name 76 | Amendment Class 76 |
| 12/13/2021 | Project Name 77 | 1100 | 1100 | Area Owner 77 | Map Name 77 | Amendment Class 77 |
| 12/13/2021 | Project Name 78 | 1100 | 1100 | Area Owner 78 | Map Name 78 | Amendment Class 78 |
| 12/13/2021 | Project Name 79 | 1100 | 1100 | Area Owner 79 | Map Name 79 | Amendment Class 79 |
| 12/13/2021 | Project Name 80 | 1100 | 1100 | Area Owner 80 | Map Name 80 | Amendment Class 80 |
| 12/13/2021 | Project Name 81 | 1100 | 1100 | Area Owner 81 | Map Name 81 | Amendment Class 81 |
| 12/13/2021 | Project Name 82 | 1100 | 1100 | Area Owner 82 | Map Name 82 | Amendment Class 82 |
| 12/13/2021 | Project Name 83 | 1100 | 1100 | Area Owner 83 | Map Name 83 | Amendment Class 83 |
| 12/13/2021 | Project Name 84 | 1100 | 1100 | Area Owner 84 | Map Name 84 | Amendment Class 84 |
| 12/13/2021 | Project Name 85 | 1100 | 1100 | Area Owner 85 | Map Name 85 | Amendment Class 85 |
| 12/13/2021 | Project Name 86 | 1100 | 1100 | Area Owner 86 | Map Name 86 | Amendment Class 86 |
| 12/13/2021 | Project Name 87 | 1100 | 1100 | Area Owner 87 | Map Name 87 | Amendment Class 87 |
| 12/13/2021 | Project Name 88 | 1100 | 1100 | Area Owner 88 | Map Name 88 | Amendment Class 88 |
| 12/13/2021 | Project Name 89 | 1100 | 1100 | Area Owner 89 | Map Name 89 | Amendment Class 89 |
| 12/13/2021 | Project Name 90 | 1100 | 1100 | Area Owner 90 | Map Name 90 | Amendment Class 90 |
| 12/13/2021 | Project Name 91 | 1100 | 1100 | Area Owner 91 | Map Name 91 | Amendment Class 91 |
| 12/13/2021 | Project Name 92 | 1100 | 1100 | Area Owner 92 | Map Name 92 | Amendment Class 92 |
| 12/13/2021 | Project Name 93 | 1100 | 1100 | Area Owner 93 | Map Name 93 | Amendment Class 93 |
| 12/13/2021 | Project Name 94 | 1100 | 1100 | Area Owner 94 | Map Name 94 | Amendment Class 94 |
| 12/13/2021 | Project Name 95 | 1100 | 1100 | Area Owner 95 | Map Name 95 | Amendment Class 95 |
| 12/13/2021 | Project Name 96 | 1100 | 1100 | Area Owner 96 | Map Name 96 | Amendment Class 96 |
| 12/13/2021 | Project Name 97 | 1100 | 1100 | Area Owner 97 | Map Name 97 | Amendment Class 97 |
| 12/13/2021 | Project Name 98 | 1100 | 1100 | Area Owner 98 | Map Name 98 | Amendment Class 98 |
| 12/13/2021 | Project Name 99 | 1100 | 1100 | Area Owner 99 | Map Name 99 | Amendment Class 99 |
| 12/13/2021 | Project Name 100 | 1100 | 1100 | Area Owner 100 | Map Name 100 | Amendment Class 100 |

Invoice 300343

12-16-21

Parker's Custom Ironworks LLC
Earl and Miranda Parker
1100 Mt. Gleason Rd.
Boonville, IN 47601
812-897-3007 office
812-457-2622 cell

Client: Warrick County Commissioners
Contact: Sherrice Stevens
Phone Number: 812-897-8637
Project Description:

Custom Light Poles (Option A) - 10 pcs. 11' overall, 7 1/2" base sketch. The proposed custom light poles will be built to match the provided sketch. The post base will be 7 1/2" wide and 24" tall. The center post will be fluted 3" round tube. The decorative light will have a 12" wide hammered shade (see photo). The light poles will be installed in the locations of the existing lights on site.

Cost: \$10,852.24

The entire project will have a black powder coated finish applied to it.

Installation: Included

Cost: \$10,852.24

Sales tax (materials): Exempt

Material Cost of \$5,426.12 due upon receipt of materials.

Invoice Total: \$5426.12

Light Post Opt A

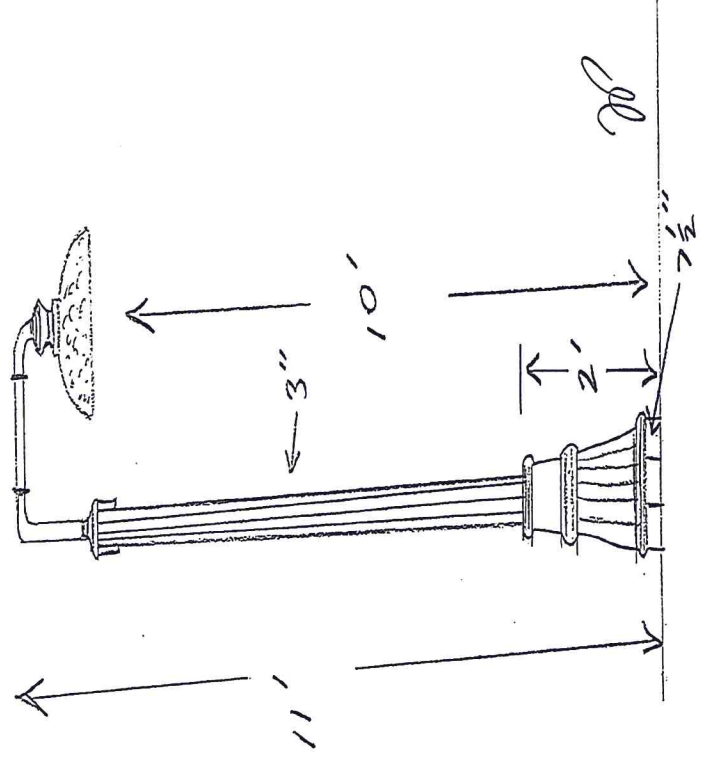

Sketch, SD

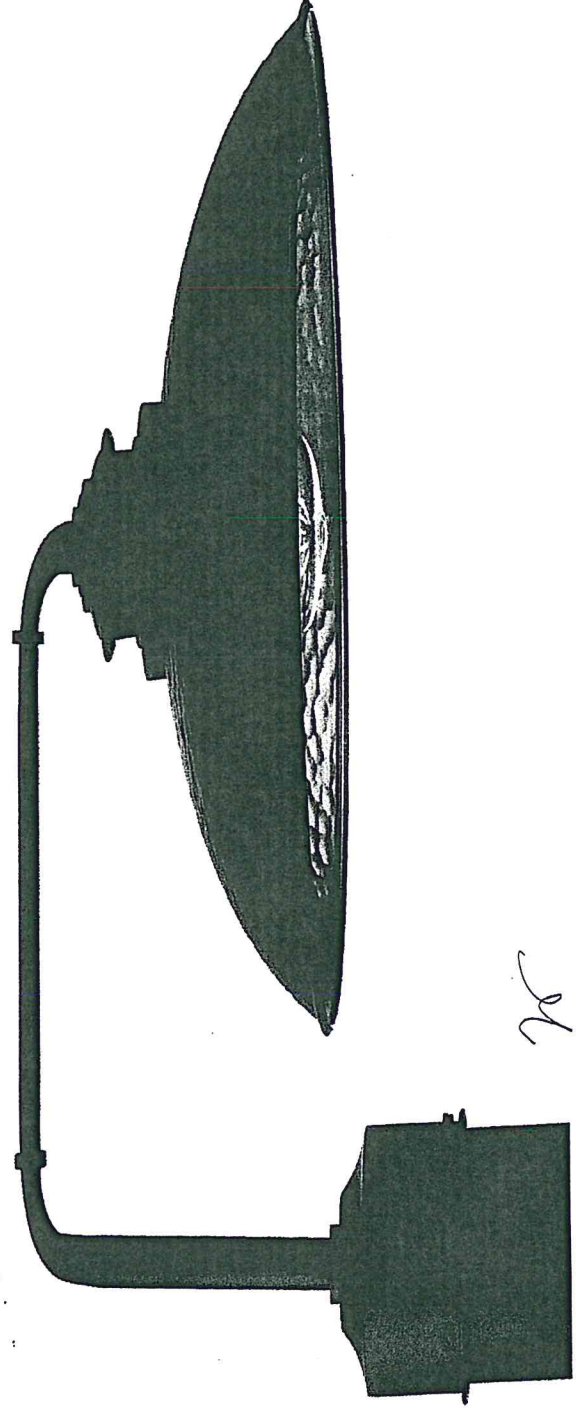

21-61

WARRICK COUNTY, INDIANA
PANDEMIC RELIEF FUND REQUEST FORM

Requesting Party: Also on department - AARON FRANZ Date: 12/13/21
Phone Number: 812-897-6105 Email Address: afraz@warrickcounty.gov
Amount Requested: 22,590.00 Designated Expense Category(ies): 1613 6 -
This Request is to: Reimburse one or more prior expenses already incurred

Description of Request and how it is necessary in response to COVID-19 pandemic:
Please see attached letter

Please see attached letter

Please attach any and all supporting documentation to this Request (e.g., quotes, proposals, invoices, etc.). Failure by a Requesting Party to include necessary Supporting Documentation will result in the rejection of this Request.

Submit this Request and copies of all Supporting Documentation to:

Roger Emmens
Warrick County Administrator
107 W. Locust Street, Suite 301
Boonville, IN 47601
roee@warrickcounty.gov

For Administrator use only

Request Number: _____ Date Received: _____
Signature: _____ Date: _____
Title: _____



December 13, 2021

Pandemic Relief Funds Request:

We are requesting the funds listed to add furniture and replace existing furniture in our main floor office of the Warrick County Health Department. An itemized list is attached to this request, the cost also includes the proper placement and finish work of the furniture (also itemized in the statement) Our workload has increased due to the managing of any and all of the State and Federal mandated work that must be done as a direct result of COVID-19. This includes, but is not limited to: Increased restaurant COVID-19 complaints about Mask violations, Contact tracing complaints, sick staff reporting to work, all business complaints regarding COVID-19 Compliance, media releases, media management of phone calls from the local paper, local TV, The Indiana State Department of Health, and state-level requests for reimbursement as planning for events, state vaccine and testing grants, grant work related to the COVID-19 pandemic as well as the corresponding grant maintenance for all Department of Education Liaison coordination as well as the State Government. All of this creates an increased workload in our office. The Work that had already been increasing in our office has increased exponentially due to the COVID-19 Pandemic. We are now the clearing house for all things COVID in Warrick County. Our office has to be not only the place where all of these pandemic things happen, we must also exemplify the message we deliver. All of which is in accordance with the Federal Government, CDC, and State Department of Health's mandates and CDC guidelines. In turn we have also had to have contractor Ralph Simpson do work in our office to help us alleviate some of our space concerns and some more work is needed in order to keep us compliant with CDC guidelines for social distancing. We are short of the furniture needed to house our current situation. What is usable of the current furniture will be given to other County offices in need of it, as deemed necessary by the County Commissioners.

Thank you for your time in this matter,

Aaron Franz
Executive Director

Warrick County Department
of Health
107 W. Locust St., Suite 107
Boonville, Indiana 47601
Telephone (812) 897-6105
Nurseries - Fax (812) 897-6410



NATIONAL BUSINESS
FURNITURE

Ship-To Address ssievers@warrickcounty.gov

SHERIE SIEVERS
ACQUISITION ADMINISTRATOR
WARRICK COUNTY
106 W LOCUST
BOONVILLE, IN 47601
(812) 897-8637

Source: 99
Cat: 46
Cust#: CE9896

Quote # QM614209 (v2)

National Business Furniture, LLC
770 South 70th Street Milwaukee, WI 53214
phone (800) 558-1010 x3541 fax: (800) 329-9349

Bill-To Address ssievers@warrickcounty.gov

SAME

| Item # | Qty | Description | Options | Lead Time | | Catalog Price | Discount Price | Total Merch |
|---------------|-----|-----------------------------|---------|-----------|---------|---------------|----------------|-------------|
| | | | | 1-2 Wks | 1-2 Wks | | | |
| 13167 DESK | 2 | Compact Executive Desk | Gray | 1-2 Wks | 1-2 Wks | \$1,149.00 | \$953.67 | \$1,907.34 |
| 13168 DESK | 3 | Compact L Desk Right Return | Gray | 1-2 Wks | 1-2 Wks | \$1,779.00 | \$1,476.57 | \$4,429.71 |
| 13346 DESK | 1 | L Desk Left Return | Gray | 1-2 Wks | 1-2 Wks | \$1,779.00 | \$1,476.57 | \$1,476.57 |
| 14243 DESK | 1 | 3 Piece Office Suite | Gray | 1-2 Wks | 1-2 Wks | \$3,199.00 | \$2,655.17 | \$2,655.17 |
| 30807 DESK | 6 | Two Drawer Lateral File | Gray | 1-2 Wks | 1-2 Wks | \$759.00 | \$629.97 | \$3,779.82 |
| 32882 DESK | 4 | Open Bookcase 72"H | Gray | 1-2 Wks | 1-2 Wks | \$629.00 | \$522.07 | \$2,088.28 |
| 32883 DESK | 3 | Bookcase w/Lower Doors | Gray | 1-2 Wks | 1-2 Wks | \$739.00 | \$613.37 | \$1,840.11 |

Important Information:

LOCATION DETAILS:
BUSINESS/MILITARY BASE/RESIDENCE: LOCAL GOVT
DOCK NO RECEIVING AREA NO ELEVATOR YES STAIR CARRY: NO
INSTALLATION DAYS/HOURS: M-F 9-5 BUILDING RESTRICTIONS: NO
SECURITY OR COVID19 SPECIFIC PROTOCOLS ON SITE: NO

| | |
|----------------------|-------------|
| Merchandise | \$21,900.00 |
| Total Discount | 3,723.00 |
| Merchandise Subtotal | 18,177.00 |
| Shipping & Handling | 1,617.00 |
| Additional Services | 2,596.00 |
| Subtotal | 22,590.00 |
| Total Tax | 0.00 |
| Order Total | \$22,590.00 |

Customer PO#: _____

Quoted By: ED MALLONEN Ext: 3541 Om: 12/09/21 Page 1

RESOLUTION 2021-18

A RESOLUTION OF THE BOARD OF COMMISSIONERS OF WARRICK COUNTY, INDIANA, ESTABLISHING A POLICY FOR CONTRIBUTIONS TO A COUNTY EMPLOYEE'S HEALTH SAVINGS ACCOUNT

WHEREAS, the Board of Commissioners of Warrick County, Indiana desires to establish a policy setting forth the premium contribution amounts to be made by Warrick County for those eligible employees who elect to participate in Warrick County's Health Savings Account plan option.

NOW, THEREFORE, BE IT RESOLVED by the Board of Commissioners of Warrick County, Indiana as follows:

In the event an eligible employee of Warrick County elects to participate in the County's Health Savings Account (HSA) plan option, regardless of the employee's health insurance coverage during the covered period, Warrick County shall make the following contributions towards said employee's HSA plan on a quarterly basis:

- 1. Employee only: \$40.01 per quarter.
- 2. Employee and spouse: \$97.00 per quarter.
- 3. Employee and children: \$158.08 per quarter.

This Policy is effective as of January 1, 2022.

Passed and adopted by the Board of Commissioners of Warrick County this 13th day of December, 2021.

WARRICK COUNTY BOARD OF COMMISSIONERS

Terry Phillippe
 Terry Phillippe, President
Robert H. Johnson, Jr.
 Robert H. Johnson, Jr., Vice President
Darr Saylor
 Darr Saylor, Member

RESOLUTION 2021-18

ATTEST:

Deborah K. Stevens
 Deborah K. Stevens, Auditor
 Warrick County, Indiana

APPROVED AS TO LEGAL FORM:

Todd I. Glass
 Todd I. Glass, Esq. #13082-18
 FINE & HATFIELD, A Professional Corporation
 520 N.W. Second Street, P.O. Box 779
 Evansville, Indiana 47705-0779
 Telephone: (812) 425-3592
 Warrick County Attorney

Ralph Simpson Services
 6019 Penceock Ct
 Evansville, IN 47715

| Job Quote | |
|-----------|-----------|
| Date | Quote # |
| 10/1/2021 | 100421001 |

| |
|------------------------------|
| Name / Address |
| Warrick County Commissioners |
| Suite 301 County Street |
| Evansville, IN 47601 |

| Description | City | Rate | Project |
|--|------|-----------|-------------|
| Site Work: remove existing cabinets, doors and shelves in West section of office North West corner of building. Install and countertops, provide access door to plumbing. touch up paint (customer provided) | | 12,797.07 | Total |
| | | | 12,797.07 |
| Total | | | \$12,797.07 |